

# Sika® Galvashield CC

## Embedded Galvanic Anode for Corrosion Control

### Product Description

Sika® Galvashield CC embedded galvanic anodes are used to control ongoing corrosion and to prevent the new formation of corrosion sites on reinforced concrete structures. The specially formulated precast cementitious mortar surrounds and activates the sacrificial zinc core. The cylinders are available in a variety of sizes and are quickly and easily installed into concrete to control corrosion activity. When correctly installed and connected the zinc anode corrodes preferentially to the surrounding steel, providing galvanic corrosion prevention and control to the adjacent reinforcement.

### Uses

- Reinforced concrete with high chloride content
- Post-tensioning anchors
- Columns and beams
- Car Parks and Bridge Decks
- Piers & Marine structures
- Pre-stressed concrete elements
- Carbonated Concrete

### Characteristics / Advantages

- **Proven technology** - supported by independent test program.
- **Focused protection** - provides localized protection where actual and potential corrosion risks are high.
- **Economical** - low cost method protecting local areas that are chloride contaminated but sound, thereby reducing concrete breakout.
- **Versatile** - effective in chloride-contaminated and carbonated concrete. Can be used for both conventionally reinforced and prestressed or post-tensioned concrete.
- **User friendly** - installation is quick and easy.
- **Low maintenance** – requires no external power source or system monitoring.
- **Measurable** – anode performance can be easily monitored if required.
- **Long lasting** – 10 to 20 year service life\* reduces the need for future repairs.
- **Full system** – can be used in conjunction with Sika FerroGard and SikaGard technology to offer a full corrosion management system.

\* As with all galvanic protection systems, service life is dependent upon a number of factors including reinforcing steel density, concrete conductivity, chloride concentration, humidity and anode spacing

Level of Protection	Level of Protection	Description	Galvashield® CC
	Corrosion Prevention 0.2 – 2mA/m <sup>2</sup>	Preventing new corrosion activity from initiating	●
	Corrosion Control 1 – 7mA/m <sup>2</sup>	Significantly reducing or stopping on-going corrosion activity	●
	Cathodic Protection 2 – 20mA/m <sup>2</sup>	Highest level of protection intended to stop on-going corrosion activity	

Construction



**Product Data**

**Form**

**Appearance**

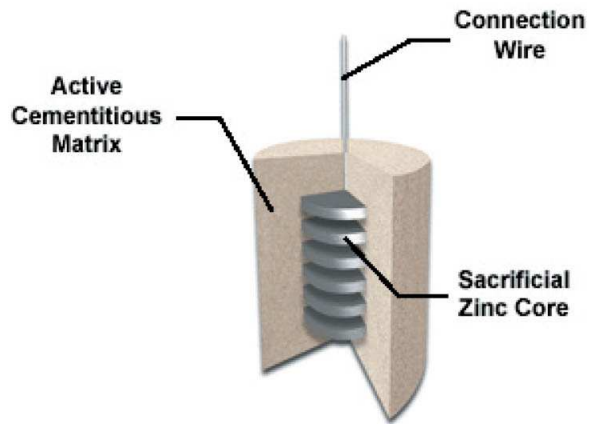

**Sika® Galvashield® CC**

**Packaging** Galvashield CC Anodes 20 anodes per box

**Storage**

**Storage Conditions/ Shelf-Life** 12 months from date of production if stored properly in original unopened, sealed and undamaged packaging in dry and cool conditions.

**Design Criteria**

**Anode Types**

Sika® Galvashield Type	Unit Size diameter x length (mm)	Minimum Hole Size diameter x depth (mm)
CC65	46 x 62	50 x 95
CC100	46 x 100	50 x 130
CC135	29 x 135	32 x 165

**Table 1**  
**Sika® Galvashield CC65 and CC135**

Steel density ratio (steel surface area/concrete surface area)	Maximum grid dimensions* (mm)
< 0.2	700
0.21 - 0.4	600
0.41 - 0.54	500
0.55 - 0.67	450
0.68 - 0.80	400
0.81 - 0.94	380
0.95 - 1.07	355
1.08 - 1.2	335

**Table 2**  
**Sika® Galvashield CC100**

Steel density ratio (steel surface area/concrete surface area)	Maximum grid dimensions* (mm)
0.55 - 0.94	500
0.95 - 1.17	450
1.18 - 1.41	400
1.42 - 1.64	380
1.65 - 1.88	355
1.89 - 2.11	335

\*Maximum grid dimensions are based on typical conditions. Spacing should be reduced as appropriate for severe environments or to extend the expected service life of the anode.

**Typical Sika® Galvashield CC series connection layout**

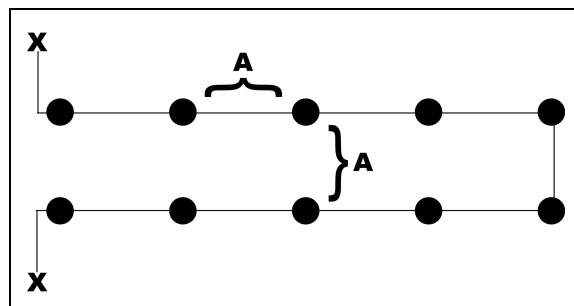

- Anode location
- X Rebar connection
- Interconnecting wire
- A Maximum spacing

## System Information

### System Structure

Sika® Galvashield CC is part of a Concrete Repair System in accordance with the guidelines of BS EN 1504

Sika® Rapid Repair Mortar: Hand Applied Mortar

Sika® MonoTop-610: Bonding primer and reinforcement coating

Sika® MonoTop-612: R4 Hand and wet spray applied repair mortar

Sika® MonoTop-615: R3 Hand and wet spray applied high build repair mortar

SikaCem 133 Gunitite R4 Dry spray applied repair mortar

Sika® MonoTop-620: Smoothing coat

Sika® FerroGard®-903: Corrosion inhibitor

Sika Galvashield Embedding Mortar: Mortar for embedding Galvashield® XP/CC

Sika Galvashield CC 65/100/135 Connection Kit: 20m Interconnecting Wire, 25 Wire Connectors, 5 x 3.2 mm stainless steel Rivets, 2 x 3.5mm drill bits

### Application Instructions

#### Application Method

The location and spacing of the Sika® Galvashield CC anodes shall be on a grid pattern as specified by the engineer. (For more information refer to Design Criteria – Tables 1 and 2). Using a rebar locator, locate all existing steel within the area designated for protection and mark areas to drill unit installation holes. Where possible, anodes should be installed a minimum of 100 mm from reinforcement grid line. Check continuity of the steel. Loss of continuity may require additional electrical connections.

#### Series Connection

- A single circuit shall contain no more than 10 Sika® Galvashield CC anodes.
- Drill a minimum of two 12 mm rebar connection holes per string of anodes.
- Saw cut a single continuous groove approximately 6 mm wide by 12 mm deep into the concrete to interconnect rebar connection holes and anode connection holes.

#### Individual Connection

- Drill one rebar connection hole per anode location.
- Saw cut a groove approximately 6 mm wide by 12 mm deep into the concrete to interconnect the rebar connection hole and anode connection hole.

#### Connections to Reinforcement

- Connections should be made by drilling into reinforcement to fix stainless steel rivet from connection kit. Secure a minimum of 5mm into reinforcement.
- Fix the interconnecting wire in place with the rivet.
- Insulate the connection with Sikaflex® 11FC.

#### Installation of CC Anodes

- Drill holes as per the dimensions listed in Anode Types table.
- Presoak the units for a minimum of 10 to a maximum of 20 minutes in a shallow water bath.
- Flush drilled holes with water to clean and remove any debris or dust and to pre-wet hole. Remove any pooled water in hole prior to application of embedment mortar.
- Sika Galvashield Embedding Mortar should be used to install the wet Sika® Galvashield CC anodes into pre-soaked (saturated-surface dry) holes.
- Place the mixed embedding mortar into the bottom 2/3 of each hole and slowly press in the anode allowing the mortar to fill the annular space ensuring there are no air voids between the anode and the parent concrete.
- The minimum concrete cover over the top of the anode shall be 20 mm.
- Connect the Sika® Galvashield CC anodes directly to the rebar connection wire using a suitable electrical wire connector.
- If installing in series, connect the units to the interconnecting wire with a suitable electrical wire connector.
- Verify continuity between anode locations and rebar connections with a multi-meter.
- A resistance of 1 ohm or less is acceptable.
- Place wires into grooves and level off anode holes and saw cuts flush with the concrete surface with Sika embedment mortar.
- Sika Galvashield Embedding mortar should be cured similar to Sika concrete repair materials and protected from traffic for 24 hours.

**Notes on Application / Limitations**

Sika® Galvashield CC anodes are not intended to address or repair structural damage. Where structural damage exists, consult a Structural Engineer.

Sika® Galvashield CC anodes are designed to provide galvanic corrosion control. Corrosion control products significantly reduce or stop on-going corrosion. Concrete patch repairs should be completed using Sika concrete repair products in accordance with BS EN 1504-3 and Sika® Galvashield XP anodes installed around the boundary of the patch or Sika® FerroGard® 903 prior to installing Sika® Galvashield CC units in the remaining unrepaired areas.

Caution should be exercised when selecting corrosion mitigation systems for post-tensioned, pre-stressed or otherwise highly stressed steel. Furthermore, the system of corrosion protection, controls and monitoring should be designed and managed by specialists who can demonstrate expertise and successful project experience.

**Local Restrictions**

Please note that as a result of specific local regulations the performance of this product may vary from country to country. Please consult the local Product Data Sheet for the exact description of the application fields.

**Health and Safety Information**

For information and advice on the safe handling, storage and disposal of chemical products, users shall refer to the most recent Material Safety Data Sheet containing physical, ecological, toxicological and other safety-related data.

**Legal Notes**

The information, and, in particular, the recommendations relating to the application and end-use of Sika products, are given in good faith based on Sika's current knowledge and experience of the products when properly stored, handled and applied under normal conditions in accordance with Sika's recommendations. In practice, the differences in materials, substrates and actual site conditions are such that no warranty in respect of merchantability or of fitness for a particular purpose, nor any liability arising out of any legal relationship whatsoever, can be inferred either from this information, or from any written recommendations, or from any other advice offered. The user of the product must test the product's suitability for the intended application and purpose. Sika reserves the right to change the properties of its products. The proprietary rights of third parties must be observed. All orders are accepted subject to our current terms of sale and delivery. Users must always refer to the most recent issue of the local Product Data Sheet for the product concerned, copies of which will be supplied on request.

Galvashield, Vector and the Vector logo are registered trademarks of Vector Corrosion Technologies Ltd.

Patents: US 6022469, 6303017, 6193857 © 2009 Vector Corrosion Technologies



Sika Limited  
 Watchmead  
 Welwyn Garden City  
 Hertfordshire  
 AL7 1BQ  
 United Kingdom  
 Phone +44 1707 394444  
 Telefax +44 1707 329129  
[www.sika.co.uk](http://www.sika.co.uk)  
 email: sales@uk.sika.com



Certificate No. EMS 4308



Certificate No. FM 12504